

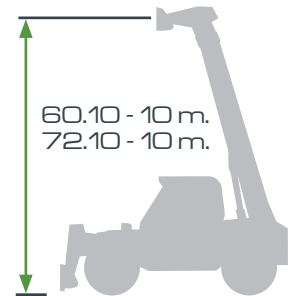

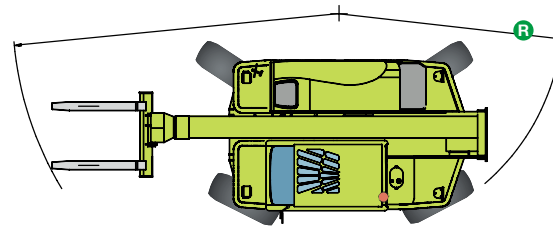

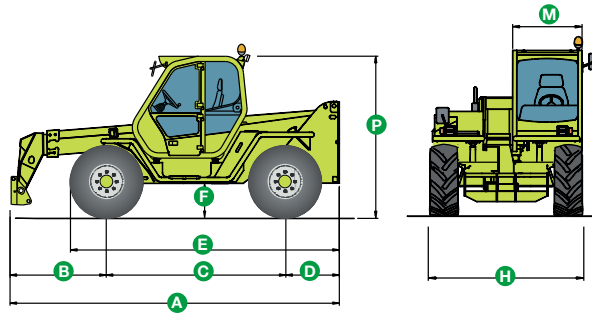

# PANORAMIC P60.10 / P72.10

	60.10	72.10
A (mm)	5345	5345
B (mm)	1235	1235
C (mm)	2875	2875
D (mm)	1300	1300
E (mm)	4645	4645
F (mm)	430	430
H (mm)	2330	2330
M (mm)	1010	1010
P (mm)	2440	2440
R (mm)	3950	3950



 <p>485 MM BODEMVRUJHEID</p>	 <p>TIER4 FINAL</p>	 <p>CRAB STEERING</p>	 <p><b>-18% VERBRUIK</b></p> <p>ECO POWER DRIVE</p>	<p><b>40 KM/U</b></p> <p>TOPSNELHEID</p>	 <p>TILT CORRECT</p>
---	--	--	--	--	---

## TOEPASSINGEN



PRODUCT  
BROCHURE



FOTO  
GALLERIJ

PERFORMANCE AND FEATURES	P60.10	P72.10	
<b>PERFORMANCES</b>			
Totale ongeladen mass zonder vorken (kg)	10000	10850	
Maximumcapaciteit (kg)	6000	7200	
Hefhoogte (m)	9,5	9,4	
Maximaal bereik (m)	5,3	5,2	
Maximale werkhoogte (m)	7,2	6	
Maximaal werkbereik (m)	1,5	1,5	
Capaciteit bij maximumhoogte (kg)	3000	4000	
Capaciteit bij maximumbereik	1500	2000	
Laterale correctie (mm)	+/- 250	+/- 250	
Nivelleringschassis (hoekcorrectie) (%)	+/- 10	+/- 10	
Mastdelen	2	2	
<b>POWERTRAIN</b>			
Motor	Tier4Final	Tier4Final	
Cylinderinhoud & aantal	3,6/4	3,6/4	
Vermogen (kW / ch.)	75/102	75/102	
Anti-pollution	EURO IV	EURO IV	
Reversible Fan	-	-	
Maximumsnelheid (km/h)	40	40	
Brandstoftank (l)	140	140	
AdBlue tank	18	18	
Hydrostatische transmissie	2 vit.	2 vit.	
EPD - ECO POWER DRIVE	standaard	standaard	
Assen	Portaal	Portaal	
Reductor	RR640	RR640	
Remmen	Schijfrem (droog)	Schijfrem (droog)	
Automatische handrem	standaard	standaard	
<b>HYDRAULICA</b>			
Pomp	LS	LS	
Debiet / Druk (l/min-bar)	108/240	108/240	
Tank	105	105	
Hydraulische aansluiting bovenaan mast	standaard	standaard	
Hydraulische aansluitingen achteraan	optioneel	optioneel	
<b>CABINE</b>			
Uitrusting	2004 CAB	2004 CAB	
MCDC	FULL	FULL	
FOPS LIV II	standaard	standaard	
ROPS	standaard	standaard	
Elektromechanische Joystick	standaard	standaard	
Elektronische Joystick	-	-	
Kantelende cabine	-	-	
Omkeerschakelaar	Finger Touch	Finger Touch	
<b>CONFIGURATIE</b>			
Cabinevering	-	-	
Mastvering	-	-	
Ophanging op de as	optioneel	-	
Werklichten op de cabine	optioneel	optioneel	
Zonnegordijn	optioneel	optioneel	
Tac-lock	standaard	standaard	
Predispositie van de werkkooi	optioneel	optioneel	
Vorken	standaard	standaard	
Pedalinching	standaard	standaard	
Aandrijving op 4 wielen	standaard	standaard	
4-wielbesturing	standaard	standaard	
Drie besturingsmodi	standaard	standaard	
Standaard banden	18-19,5"	18-19,5"	
Rotatie van de toren	-	-	
Stabilisators	-	-	
PTO	-	-	
Homologatie als landbouwvoertuig	-	-	
3-punts hefinrichting	-	-	